

DATA SHEET

VT 4.8

ROTARY VANE VACUUM PUMPS

oil-free

air-cooled

MAKE IT BECKER.

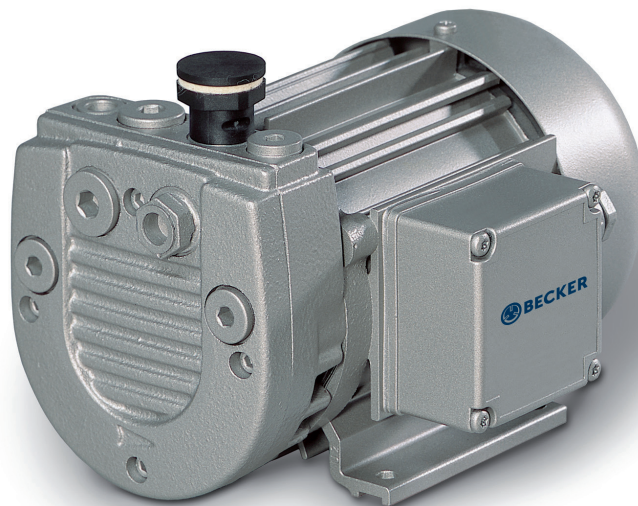

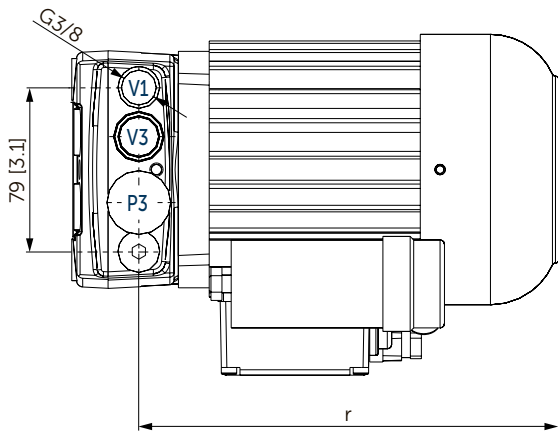
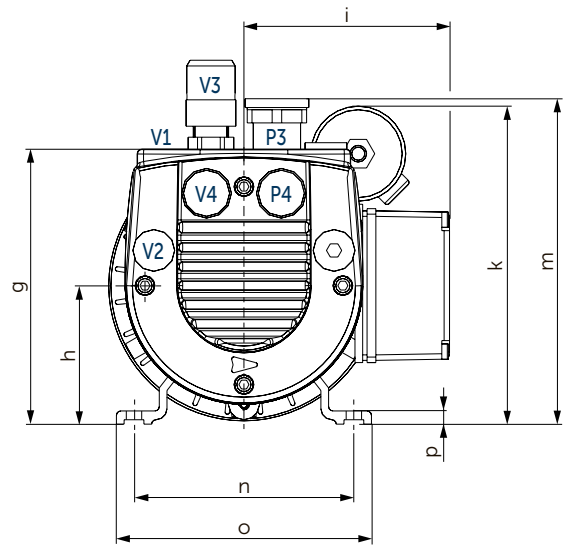
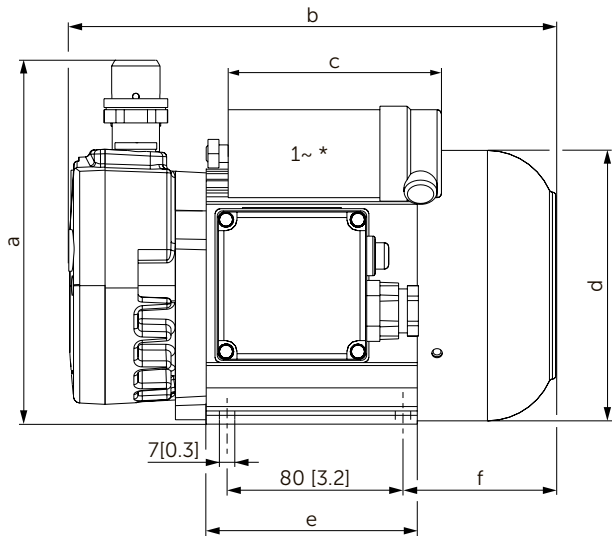

V1 (V2) Vacuum connection (G^{3/8})

V3 (V4) Vacuum regulating valve

P3 (P4) Blow-off valve

(XX) Alternative

- * The size and position of the capacitor can change with changed voltage / frequency.
- Including integrated suction air filter
- The motor illustration may vary
- Dimensions in mm [inch]

Motors		mm [inch]														
#		a	b	c	d	e	f	g	h	i	k	m	n	o	p	r
3~	01	179.5 [7.1]	250 [9.9]	-	141 [5.6]	101 [4.0]	82.5 [3.3]	139 [5.5]	71 [2.8]	101 [4.0]	-	162 [6.4]	112 [4.4]	136 [5.4]	7 [0.27]	219 [8.6]
3~	02+03	171.5 [6.8]	231 [9.1]	-	125 [4.9]	96 [3.9]	69.5 [2.7]	131 [5.2]	63 [2.5]	93 [3.7]	-	154 [6.1]	100 [3.9]	116 [4.6]	6 [0.24]	198 [7.8]
1~	01+02	171.5 [6.8]	251 [9.9]	≈94 [≈3.7]	125 [4.9]	116 [4.6]	89.5 [3.5]	131 [5.2]	63 [2.5]	93 [3.7]	143 [5.6]	154 [6.1]	100 [3.9]	116 [4.6]	6 [0.24]	198 [7.8]

Suction air rate		Vacuum absolute		Emission sound pressure level ¹⁾		Weight incl. motor ²⁾
m ³ /h		mbar		dB(A)		kg
50 Hz	60 Hz	50 Hz	60 Hz	50 Hz	60 Hz	
8.0	9.1	150	150	58	61	≈9.5

¹⁾ According to DIN EN ISO 3744 (KpA = 3 dB(A)), 1 m [39.4 inch] distance, at medium load, both connection sides piped

²⁾ Depending on the motor

3~ Motors											
#	50 Hz					60 Hz					Version
	kW	V	rpm	A	kW	V	rpm	A			
01	0.37	Δ230/Y400	IE2	2920	2.30/1.33	0.44	Δ265/Y460	IE3	3515	2.13/1.23	CE IP55 • ISO F • bimetal
						0.37	Δ230/Y400	IE3	3480	1.90/1.10	
						0.44	Δ208/Y360	IE4	3455	1.90/1.10	
02	0.37	175–260/ 300–450		2800	2.35/1.35	0.44	202–300/ 350–520		3150	2.40/1.40	IP54 • ISO F
03	0.37	175–260/ 300–450		2800	2.35/1.36	0.44	202–300/ 350–520		3150	2.40/1.40	UL • CSA IP54 • ISO F

1~ Motor											
#	50 Hz					60 Hz					Version
	kW	V	rpm	A	kW	V	rpm	A			
01	0.35	230 ±10%	2700	3.9	0.42	230 ±10%	3200	3.4	CE IP54 • ISO F • bimetal 10 μF (450 V)		
02	0.35	115 +5%/-10%	2750	7.8	0.42	110–120 ±10%	3250	6.2	CE • UL(E123782) • CSA IP54 • ISO F 40 μF (240 V)		

- Current consumption and rotation speed may vary. Tolerance in each case -1.5/+2%

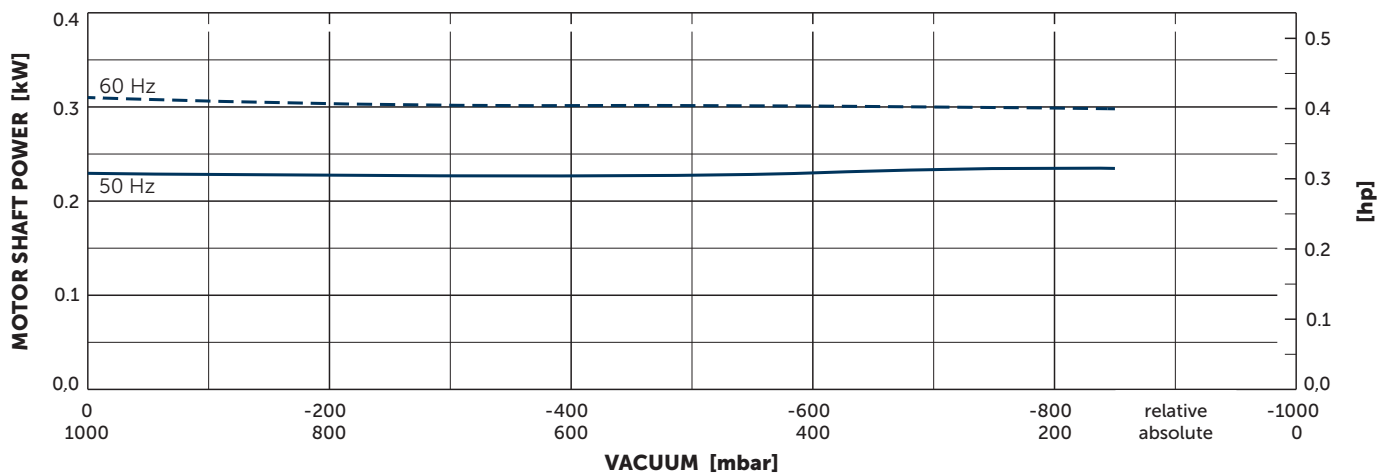
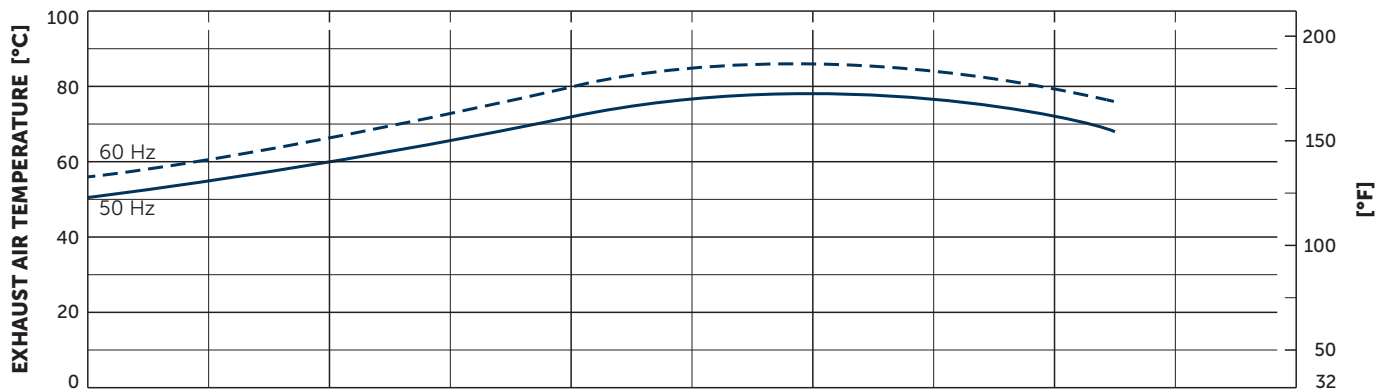
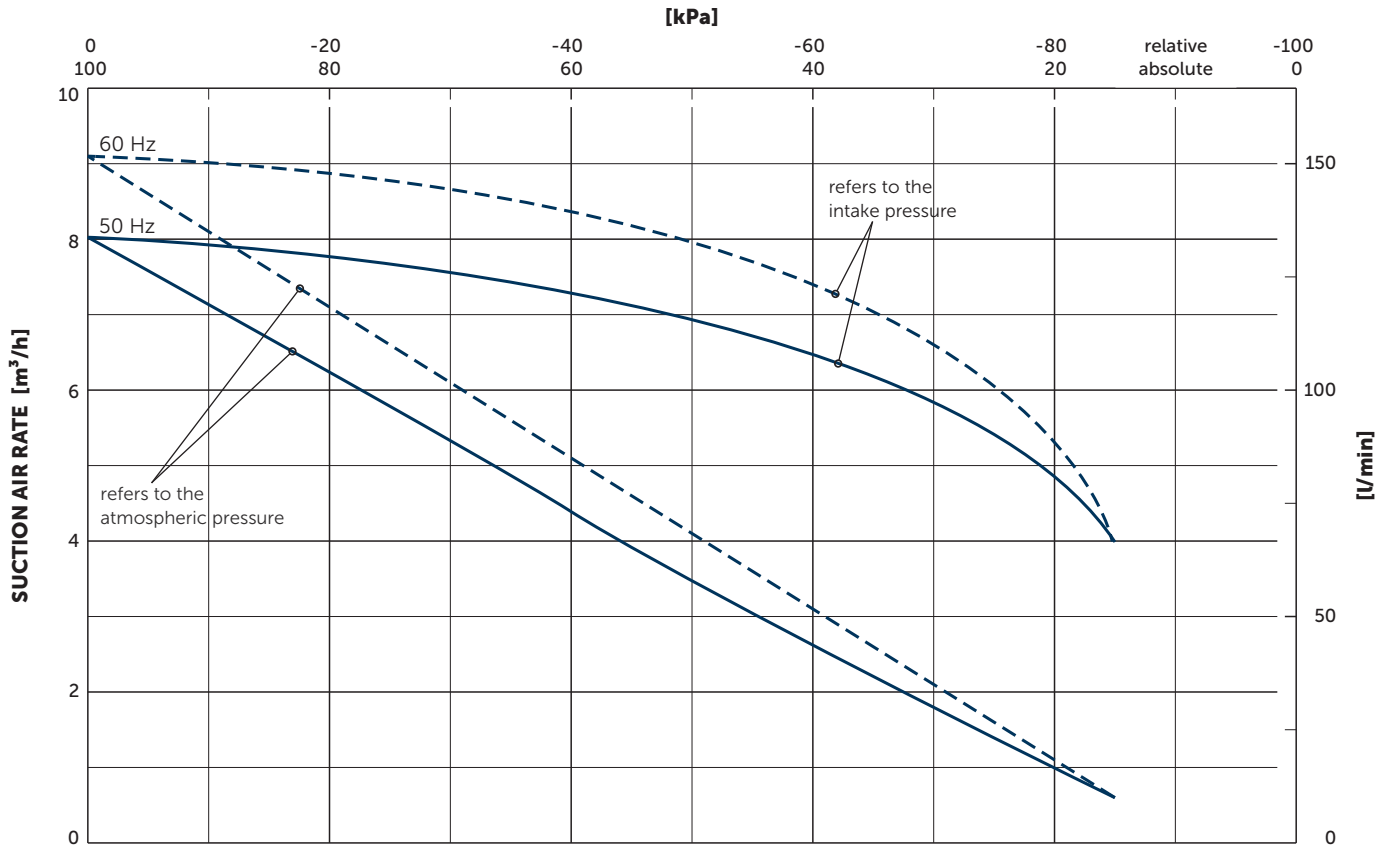

Reference data (atmosphere): 1000 mbar (100 kPa), 20°C (68°F)
Tolerance: ±10%

+ VARIANTS AND ACCESSORIES

VT 4.8 DC¹⁾

- with 24V DC motor

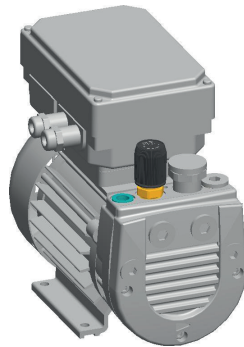

VT 4.8/0-28

- with handle

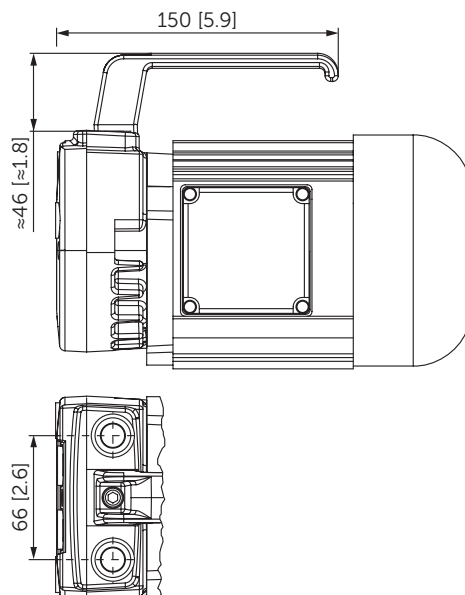

PEDESTAL ADAPTER T4.8-0-24.1

- for VT 4.8 with IE motor for replicating the pedestal bore pattern of the wide range motor
- order number: 57040027200
- scope of delivery:
 - 2 pedestal adapters
 - 4 rubber buffers with threaded pins M6
 - 4 nuts M6
 - 4 hexagon socket screws M6x25
 - 8 washers

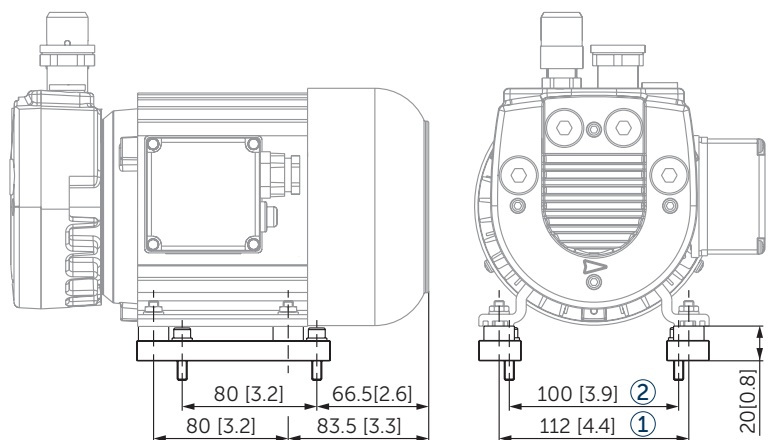

- 1 pedestal dimension of IE motor
- 2 corresponds to pedestal size of wide-range motor

¹⁾ See separate data sheet

• Dimensions in mm [inch] – For other dimensions, see the figure on page 2.



MAKE IT BECKER.